

Grounding Spring Mid Clamp

	Part #	Module Thickness (mm)	Finish
	GR-MC-GSP-3035-BLK	30-35	Black
	GR-MC-GSP-3546-BLK	35-46	
	GR-MC-GSP-4550-BLK	45-50	



Features:

- Weight: 0.11lb (Including Hardware)
- Mid Clamp Material: 300 series stainless steel
- Hardware Material: 300 series stainless steel
- Preassembled
- Integrated Grounding System
- Conforms to UL STD 2703



Grounding Mid Clamp

Installation Overview

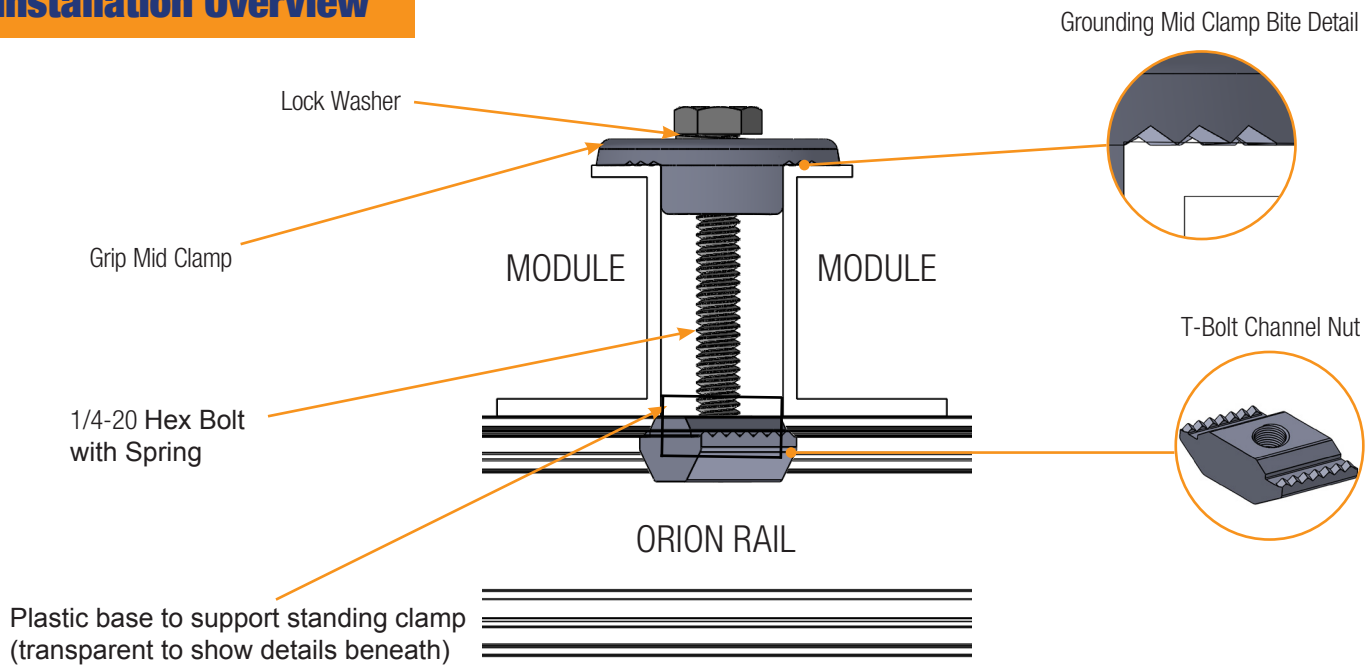

- Place Mid Clamps between modules at suggested span per module manufacturer's specification.
- Mount Mid Clamp such that modules are spaced evenly and in line with integrated spacers.
- Ensure that the channel nut "grabs" rail intrusion, and tighten hex bolt to **65** in-lbs of torque.

